

FLIGHT  
OPERATIONS  
ENGINEERING



# Range of V1

**Rob Root**

**Performance Engineer Operations**

**Boeing Commercial Airplanes**

**October 2006**

# What is V1?

**V<sub>1</sub>** is the speed at which the takeoff should be continued unless the stopping maneuver has already been initiated

## “Pilot’s” definition of V1 (AC 120-62)

V1 - The speed selected for each takeoff, based upon approved performance data and specified conditions, which represents:

- The **maximum speed** by which a rejected takeoff must be initiated to assure that a safe stop can be completed within the remaining runway, or runway and stopway;
- The **minimum speed** which assures that a takeoff can be safely completed within the remaining runway, or runway and clearway, after failure of the most critical engine at a designated speed; and

The **single speed** which permits a successful stop or continued takeoff when operating at the minimum allowable field length for a particular weight.

# Range of V1

- **Definitions**
- Physical Representation
- Graphical Presentation
- Available V1 Range
- Examples
- Reduced V1 Policy

# Definitions

- $V_{EF}$  Engine Failure Speed - The speed at which the critical engine becomes inoperative
- $V_R$  Rotation Speed - The speed at which the rotation from three point attitude to the takeoff attitude is initiated.
- $V_{LOF}$  Lift-off Speed - The speed at which the airplane becomes airborne.
- $V_2$  Takeoff Safety Speed - The target speed to be attained at the screen height (e.g. 35 ft), assuming one engine inoperative and rotation initiated at VR

## Definitions (cont'd)

- $V_{MCG}$  Ground Minimum Control Speed - The speed during the takeoff run at which, when the critical engine is suddenly made inoperative, it is possible to maintain directional control of the airplane using rudder alone, without deviating from the runway centerline by more than 30 ft.
- $V_{MBE}$  Maximum Brake Energy Speed - The highest speed from which the airplane may be brought to a stop without exceeding the maximum energy absorption capability of the brakes. Maximum Brake Energy Speed is compared in takeoff planning to  $V_1$ .

## Definitions (cont'd)

- **V1/VR** Speed Ratio - The ratio of V1 to the rotation speed VR. Used to generalize data for graphical presentation.
- Standard V1/VR - The V1/VR speed ratio defined by the one engine inoperative field length limited condition. Commonly used in Boeing takeoff analysis software.

# Range of V1

- Definitions
- **Physical Representation**
- Graphical Presentation
- Available V1 Range
- Examples
- Reduced V1 Policy

# V1 is selected to ensure:

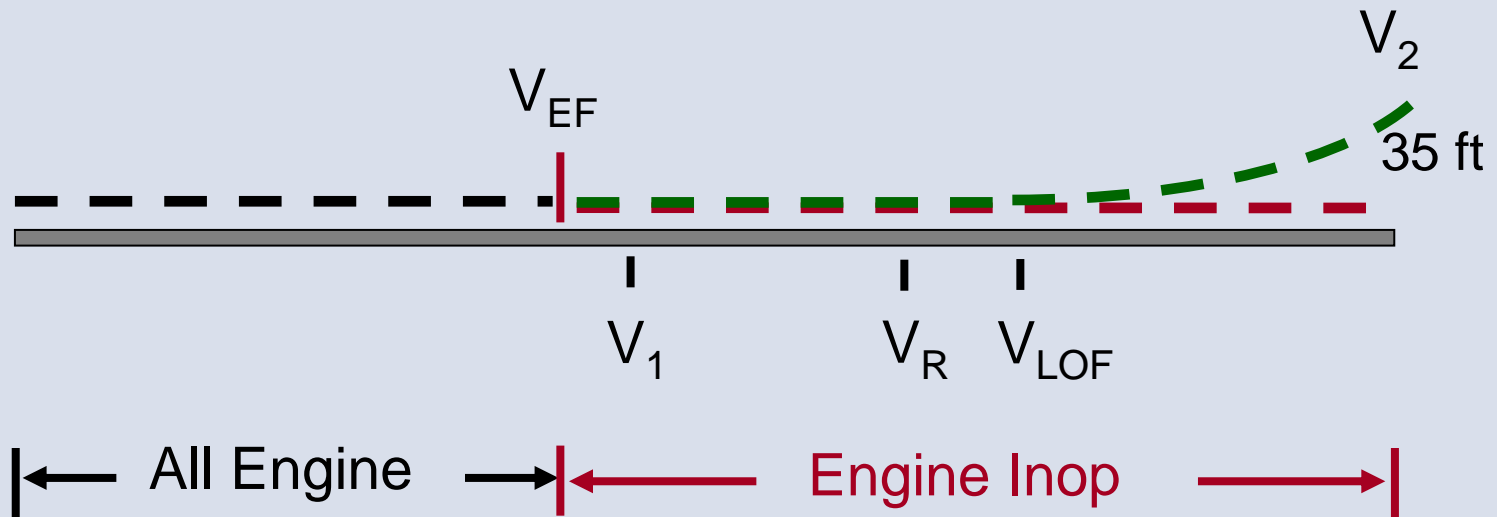

- Stop on available surface
- Go with engine inoperative
- Greater than or equal to VMCG
- Less than or equal to VR
- Less than or equal to VMBE

# FAR takeoff field length is the longer of:

## Engine Inoperative Accelerate-Go Distance:

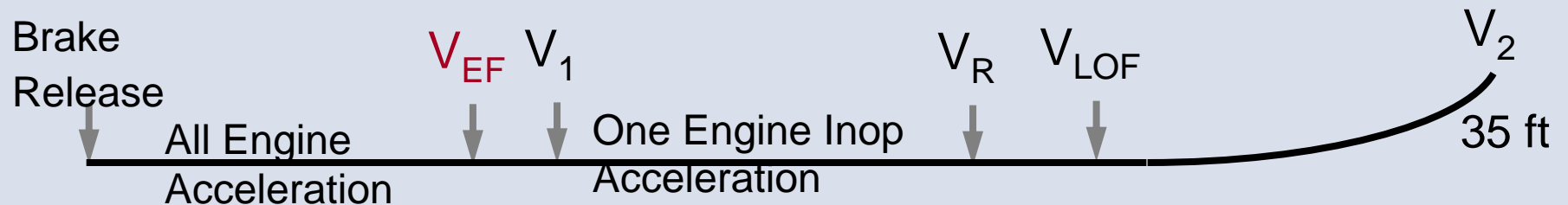

## Accelerate-Stop Distance:

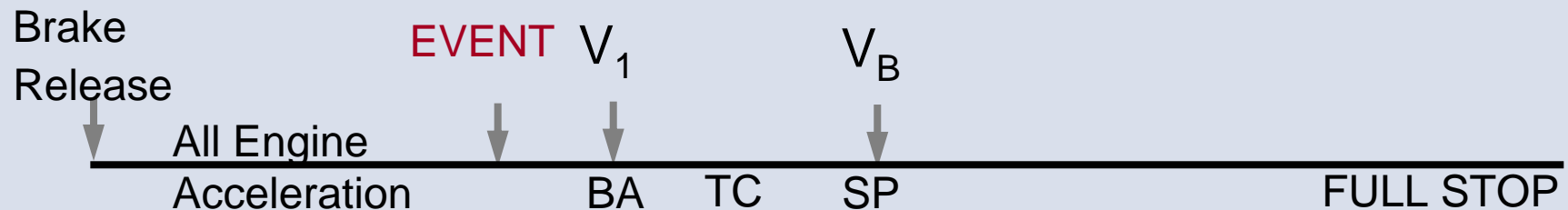

## 115% All Engine Distance to 35 ft:

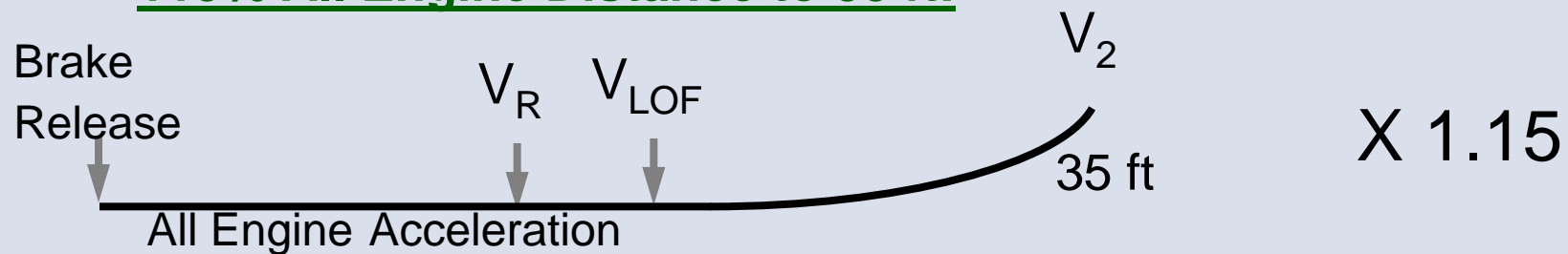

# V1 - Distance Relationships

(Constant Gross Weight)

Low V1



# V1 - Distance Relationships

(Constant Gross Weight)

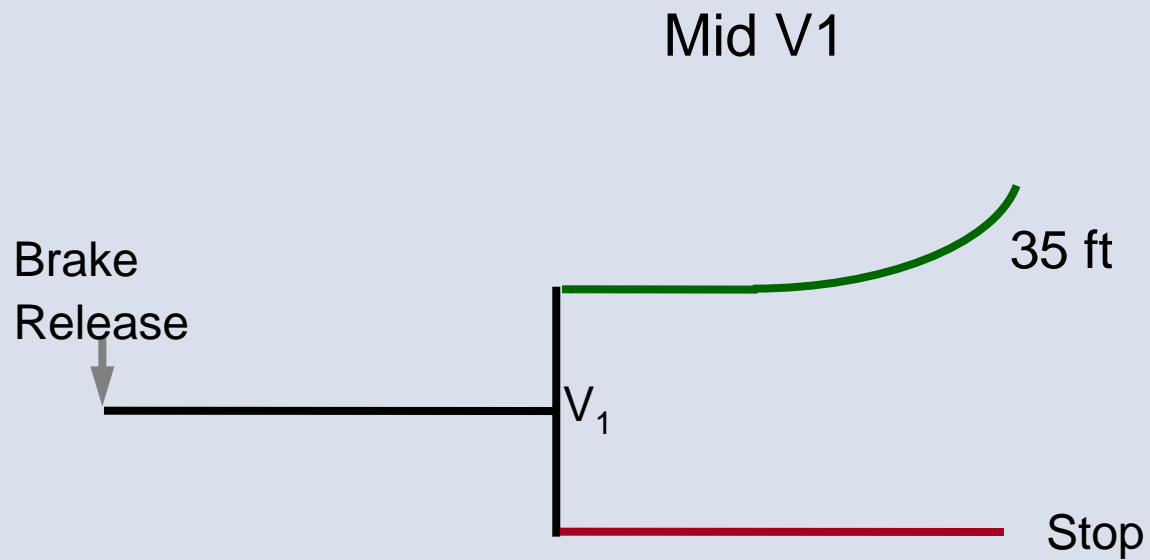

# V1 - Distance Relationships

(Constant Gross Weight)

High V1

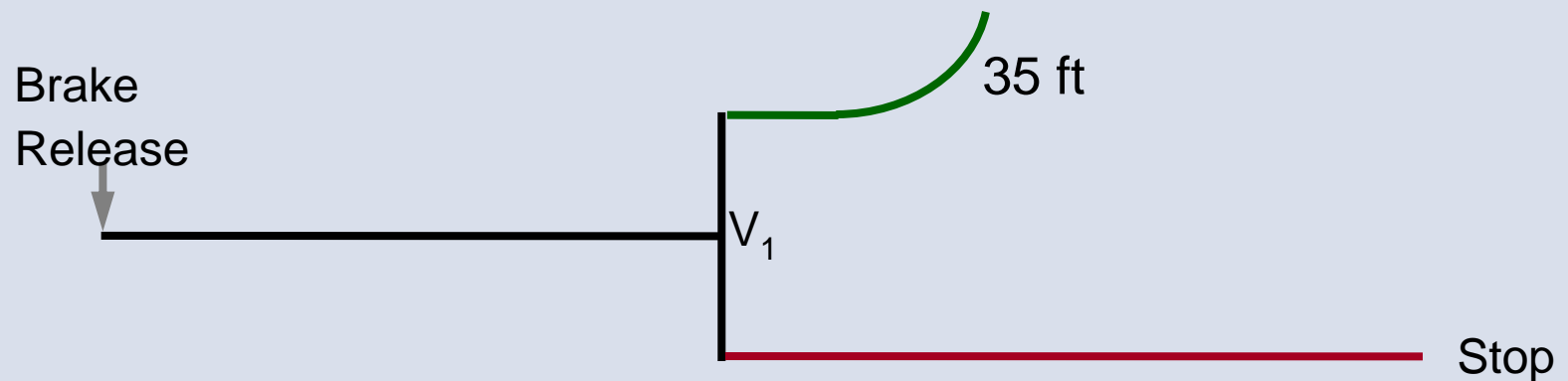

*Note: 115% All Engine Takeoff Distance is  
not affected by V1 choice*

## Why a range of V1?

EVEN THOUGH ANY VALUE IN THE ALLOWABLE RANGE OF V1 MEETS REGULATORY REQUIREMENTS, ONLY **ONE V1** SHOULD BE SELECTED FOR EACH SCHEDULED TAKEOFF. TO AID IN THIS SELECTION, THE FOLLOWING FACTS SHOULD BE CONSIDERED:

# Why a range of V1 ?(cont'd)

## **WHEN A LOW V1 IS SELECTED**

(FOR A CONSTANT GROSS WEIGHT...)

1. The stopping margins are increased for a rejected takeoff. (increased stopping margin is helpful on runways with reduced braking capability)
2. There is additional margin from Brake Energy Limits
3. There may be only the minimum required clearance over the end of the runway if it is necessary to continue the takeoff after an engine failure

## Why a range of V1 ?(cont'd)

### **WHEN A HIGH V1 IS SELECTED:**

(FOR A CONSTANT GROSS WEIGHT...)

1. The margins are increased for a continued takeoff.  
(required takeoff distance is less; V2 is reached at an earlier point along the runway)
2. There is additional margin from Ground Minimum Control Limits
3. There may be only the minimum required on stopping distance (the entire runway may be required if the takeoff is rejected at V1)

# Range of V1

- Definitions
- Physical Representation
- **Graphical Presentation**
- Available V1 Range
- Examples
- Reduced V1 Policy

# 767-300ER / CF6-80C2B6/B6F distances

TEMP = 15C  
 ELEV = SEA LEVEL  
 NO WIND  
 NO SLOPE  
 A/C ON  
 FLAPS 5

	V1	Accel-Go	Accel-Stop
180000 kg	130 kts	12050 ft	6025 ft
	140 kts	11220 ft	6910 ft
	150 kts	10250 ft	7890 ft
170000 kg	130 kts	10050 ft	5710 ft
	140 kts	9300 ft	6540 ft
	150 kts	8430 ft	7450 ft
160000 kg	130 kts	8440 ft	5310 ft
	140 kts	7660 ft	6190 ft
	150 kts	6870 ft	7050 ft

# V1 Effect on Accel-Go and Accel-Stop

(X-Plot)

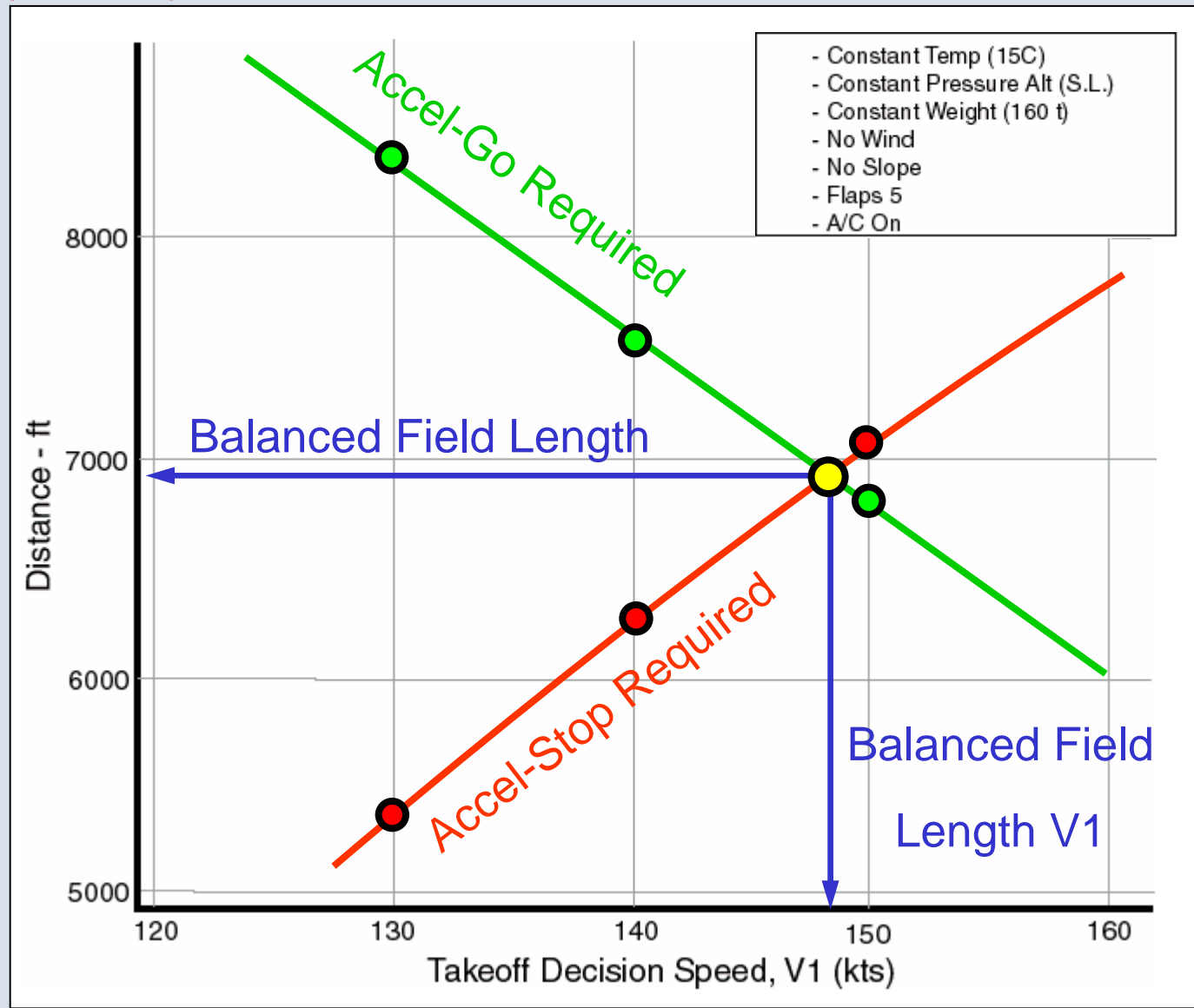

# V1 Effect on Accel-Go and Accel-Stop

("Web" chart)

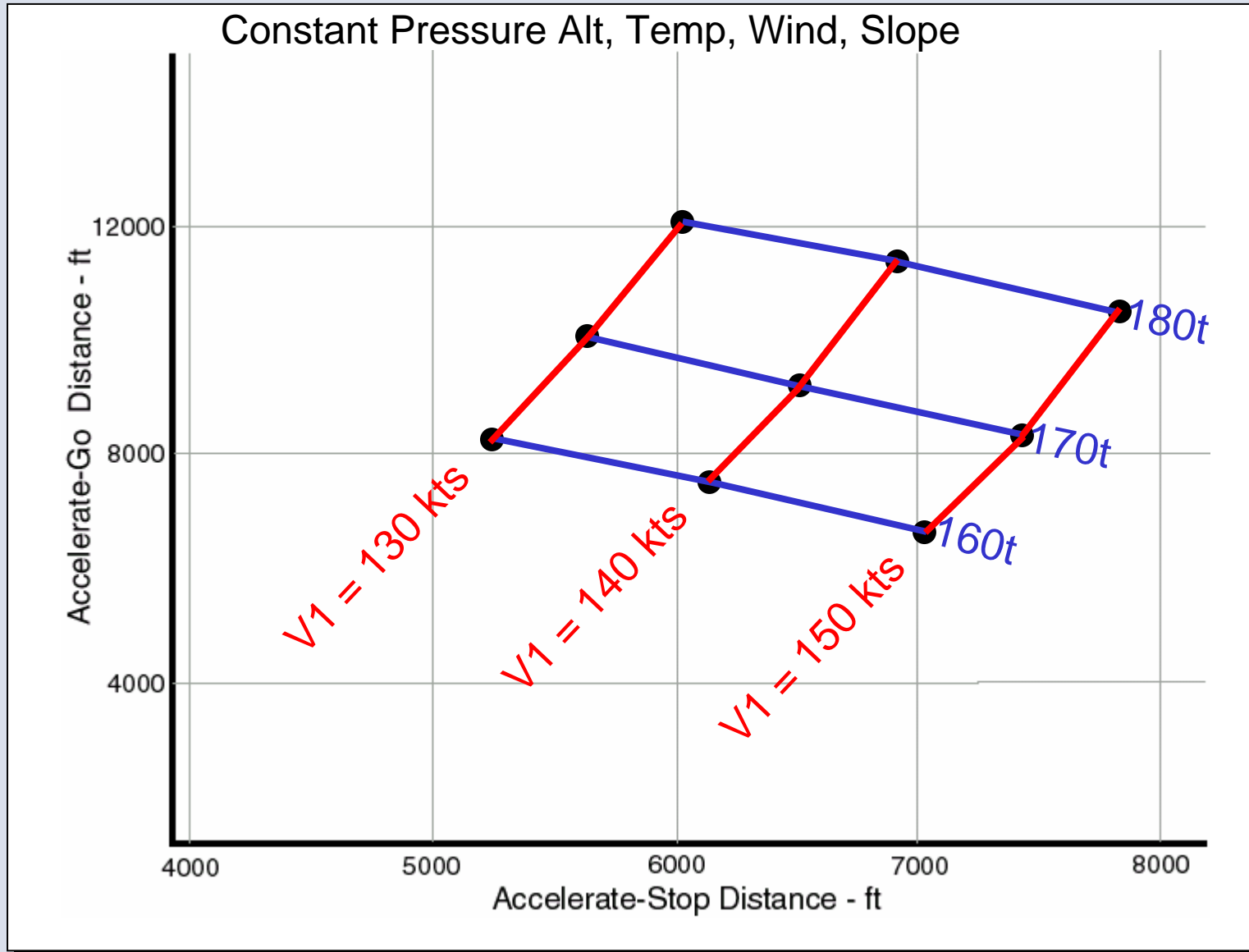

# Runway Length and V1 Adjustments (Web Chart)



# Runway Length and V1 Adjustments (Web Chart)

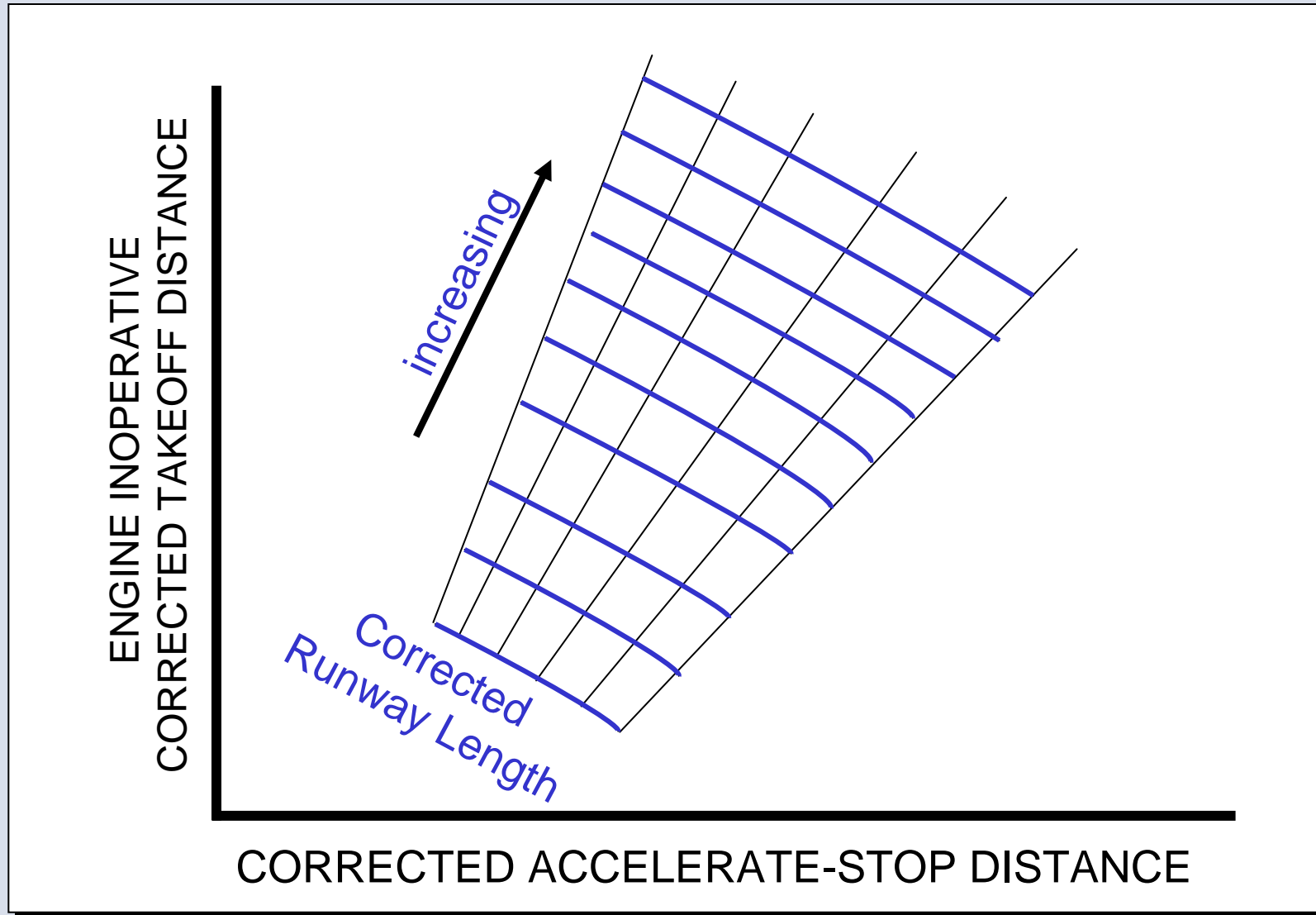

# Corrected Runway Length:

One Engine Inoperative

## **Corrected Runway Length**

(CRL) generalizes:

- **Altitude**
- **Temperature**
- **Gross Weight**

# Corrected Runway Length Required

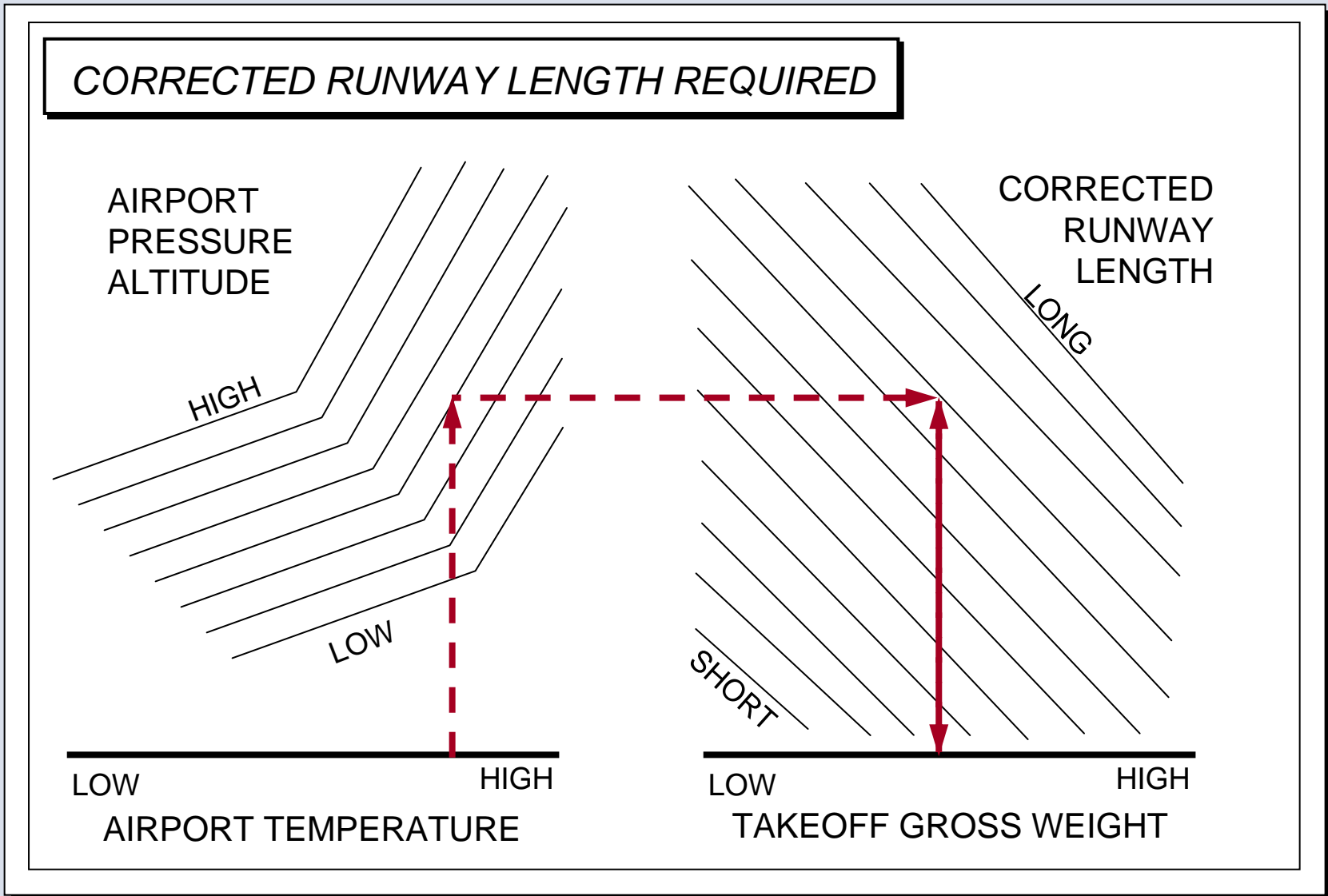

# Engine Inoperative Corrected Takeoff Distance

## ENGINE INOPERATIVE **CORRECTED** TAKEOFF DISTANCE

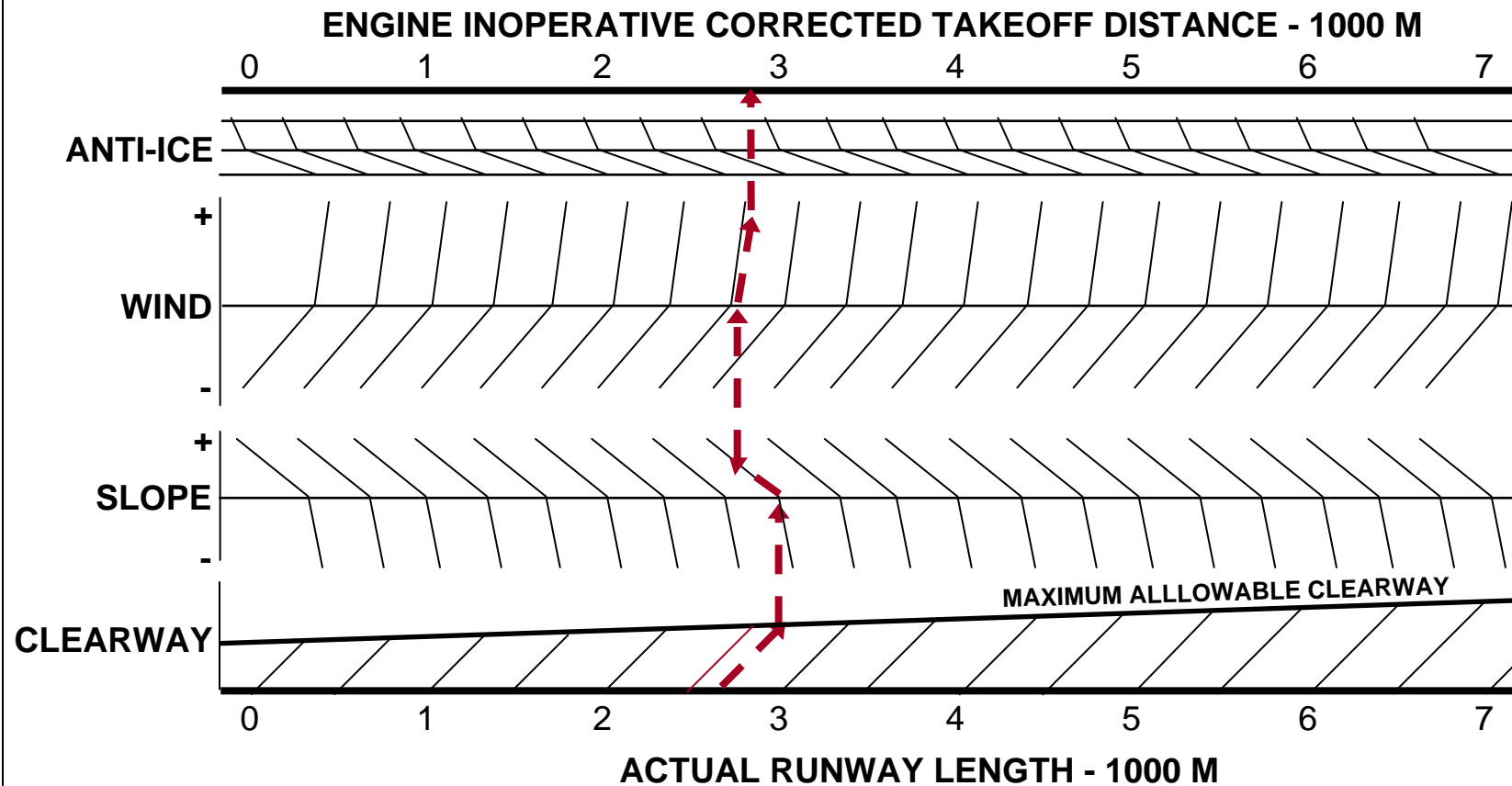

# Corrected Accelerate-Stop Distance

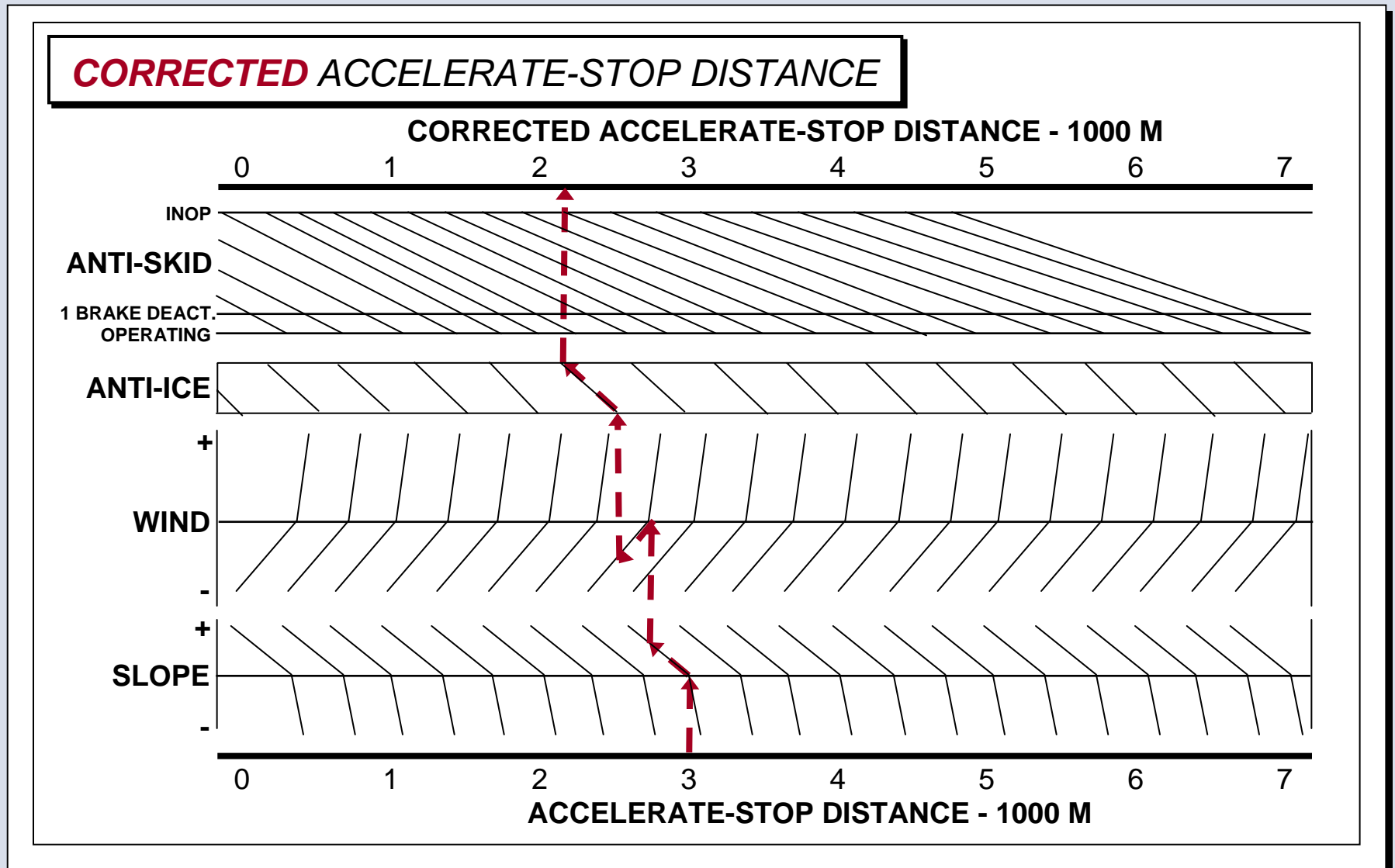

# Takeoff Speeds

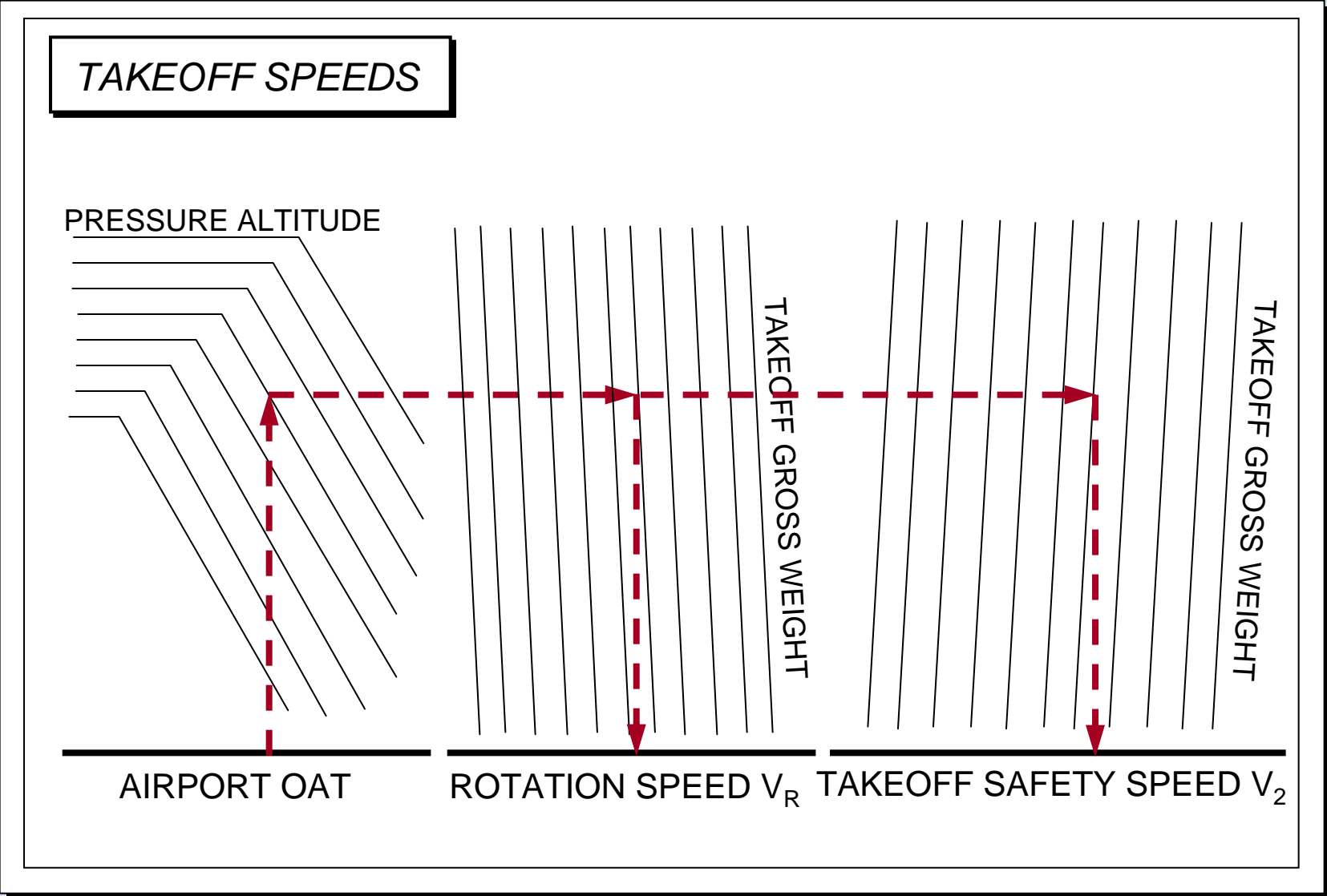

# Range of V1

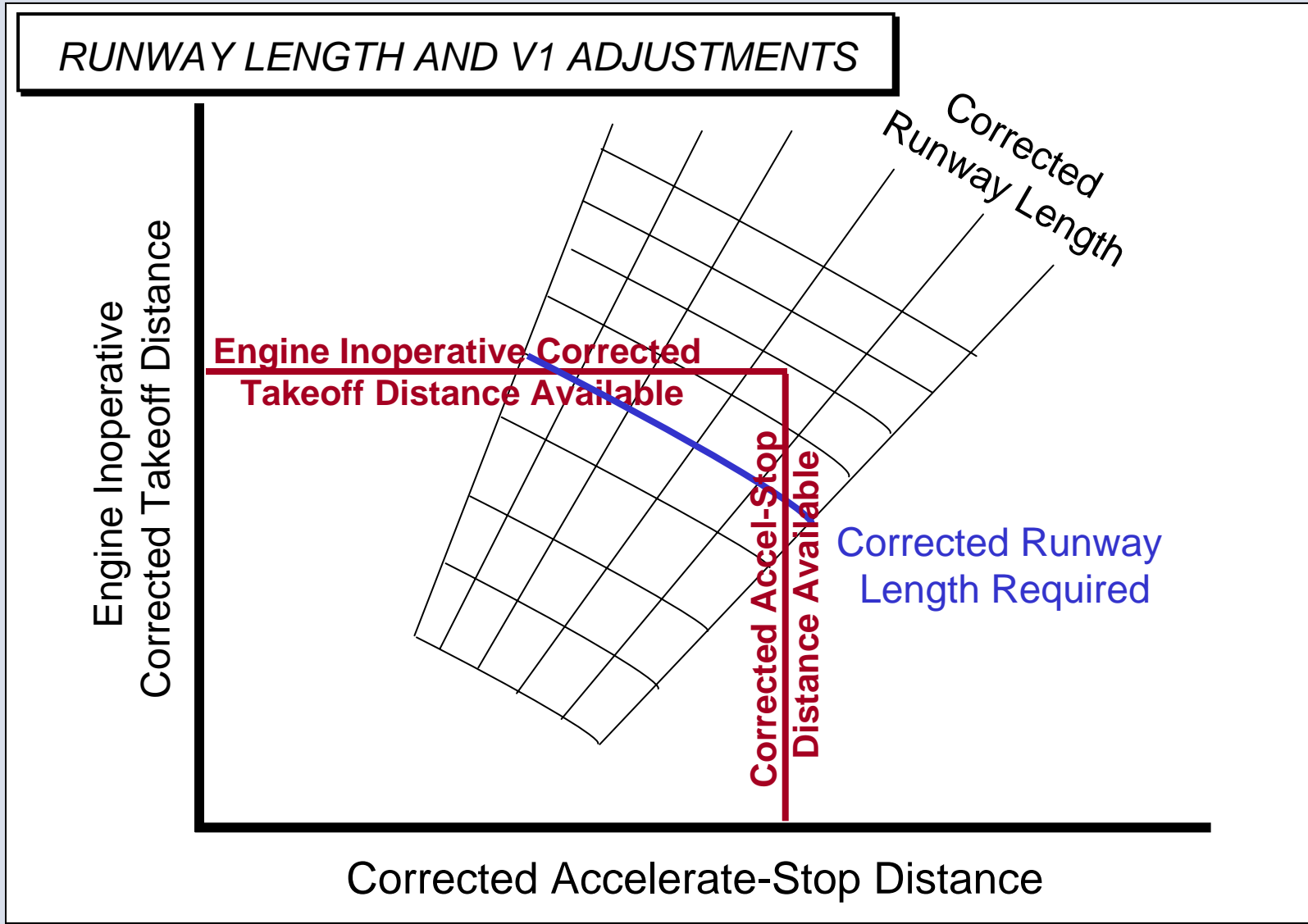

# Range of V1

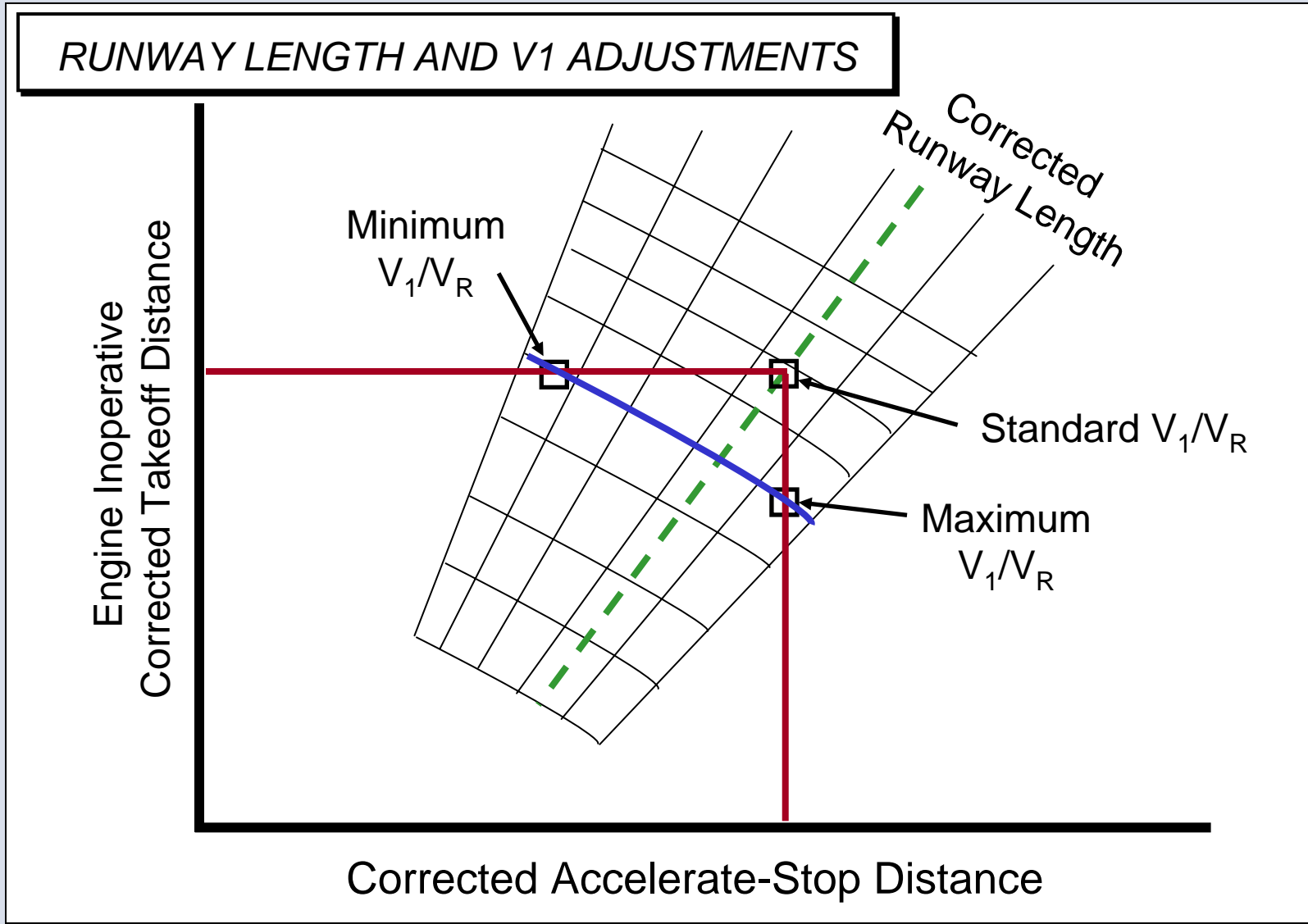

# Determining a Range of V1

## USING THE AFM SECTION 4, PERFORMANCE CHARTS

- 1.DETERMINE THE **CORRECTED RUNWAY LENGTH REQUIRED** FOR THE TAKEOFF GROSS WEIGHT, AIRPORT TEMPERATURE, AND PRESSURE ALTITUDE.
- 2.DETERMINE THE **ENGINE INOPERATIVE CORRECTED TAKEOFF DISTANCE AVAILABLE**.
- 3.DETERMINE THE **CORRECTED ACCELERATE-STOP DISTANCE AVAILABLE**.
- 4.DETERMINE **(V1/VR)MIN** FROM THE RUNWAY LENGTH AND V1 ADJUSTMENT (WEB) CHART USING THE ENGINE INOPERATIVE CORRECTED TAKEOFF DISTANCE AVAILABLE (FROM 2), AND THE CORRECTED RUNWAY LENGTH REQUIRED (FROM 1).
- 5.DETERMINE **(V1/VR)MAX** FROM THE WEB CHART USING THE CORRECTED ACCELERATE-STOP DISTANCE AVAILABLE (FROM 3), AND THE CORRECTED RUNWAYLENGTH REQUIRED (FROM 1).
- 6.DETERMINE ROTATION SPEED VR, FOR THE TAKEOFF GROSS WEIGHT AND AIRPORT TEMPERATURE AND PRESSURE ALTITUDE.
- 7.DETERMINE **V1 MIN** AND **V1 MAX** BY MULTIPLYING THE APPROPRIATE V1/VR RATIOS BY VR.

## Determining a Range of $V_1$ :

NOTE:  $V_{1MIN}$  and  $V_{1MAX}$  are the lowest and highest values of  $V_1$  that will satisfy all the Federal Aviation Regulations related to Maximum Takeoff Gross Weight, Field Length Limits.  $V_1$  must not be greater than  $V_{MBE}$  or  $V_R$ , nor less than  $V_{MCG}$

# Range of V1 Determination

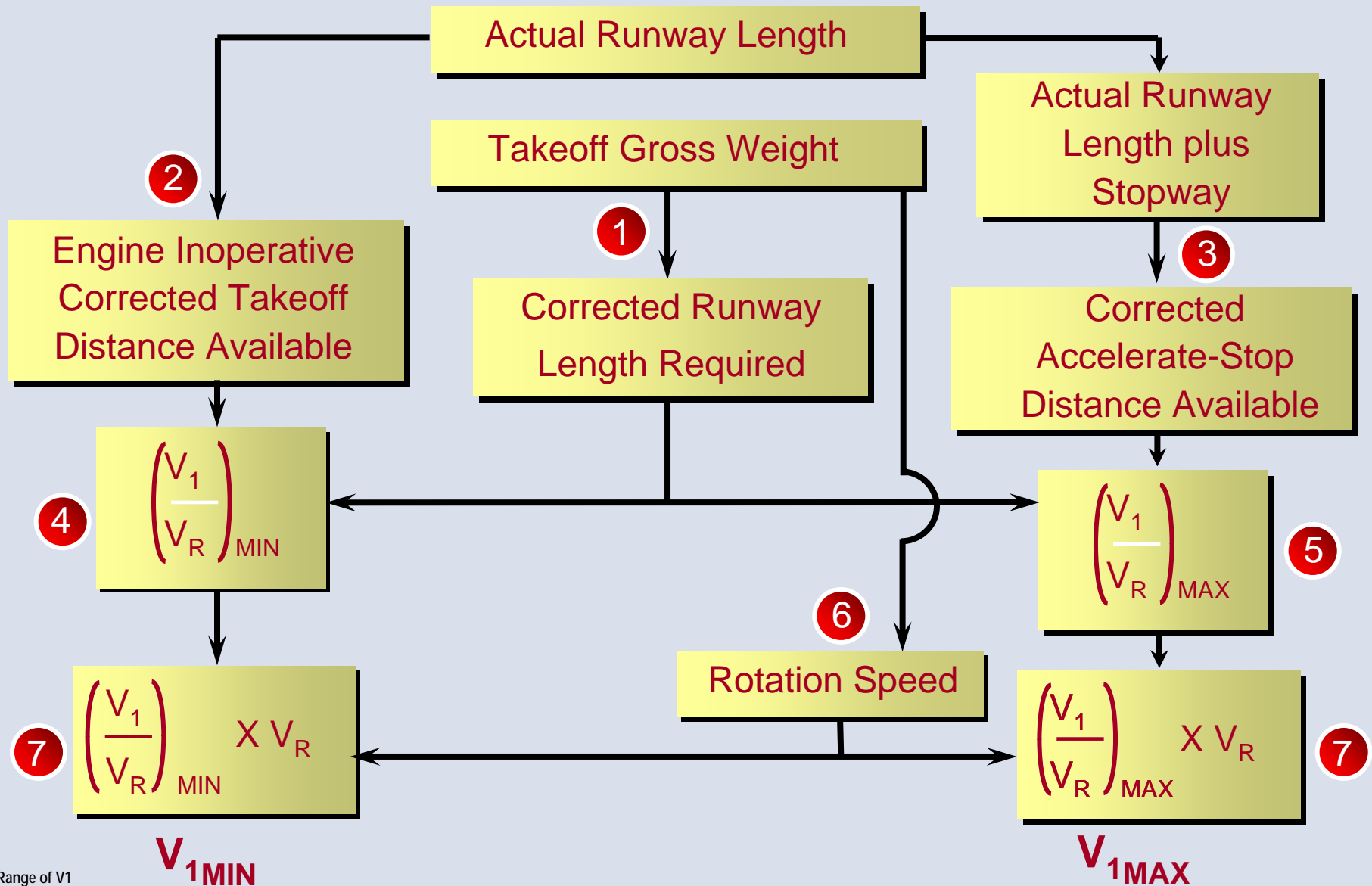

## Example Conditions:

- 767-300ER / CF6-80C2B4
- FLAPS 5
- A/C ON
- ANTI-ICE OFF
- TAKEOFF GROSS WEIGHT = 335,000 LB
- AIRPORT PRESSURE ALTITUDE = 5000 FT
- AIRPORT TEMPERATURE = 35 DEG C
- RUNWAY LENGTH = 10500 FT
- SLOPE = -1%
- WIND = 11 KTS HEADWIND
- NO CLEARWAY OR STOPWAY

# Class Problems:

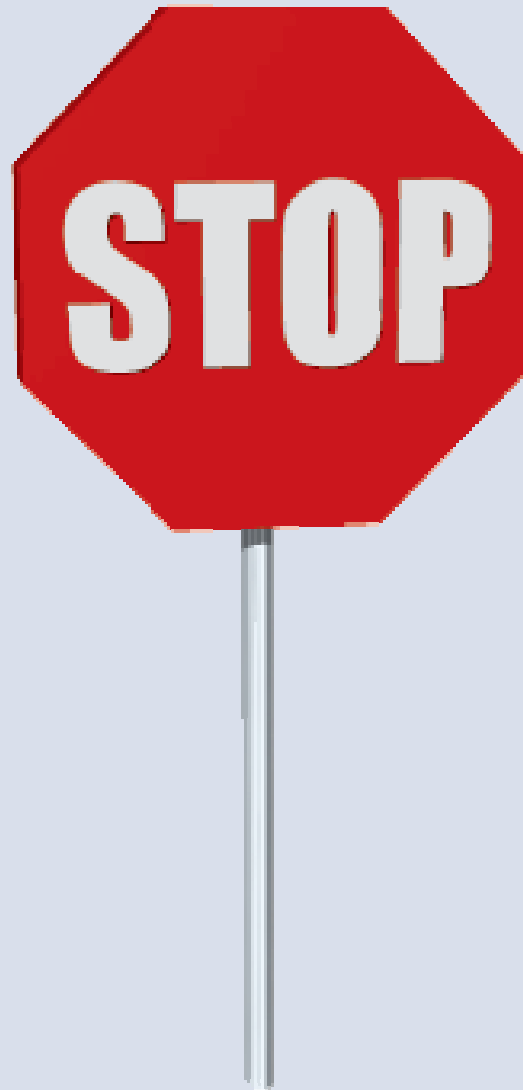

Problem Set

# Minimizing V1

At weights below the maximum takeoff weight:

When your dispatch weight is below the maximum allowed, V1 can be reduced while remaining within the takeoff distance allowed

# Range of V1

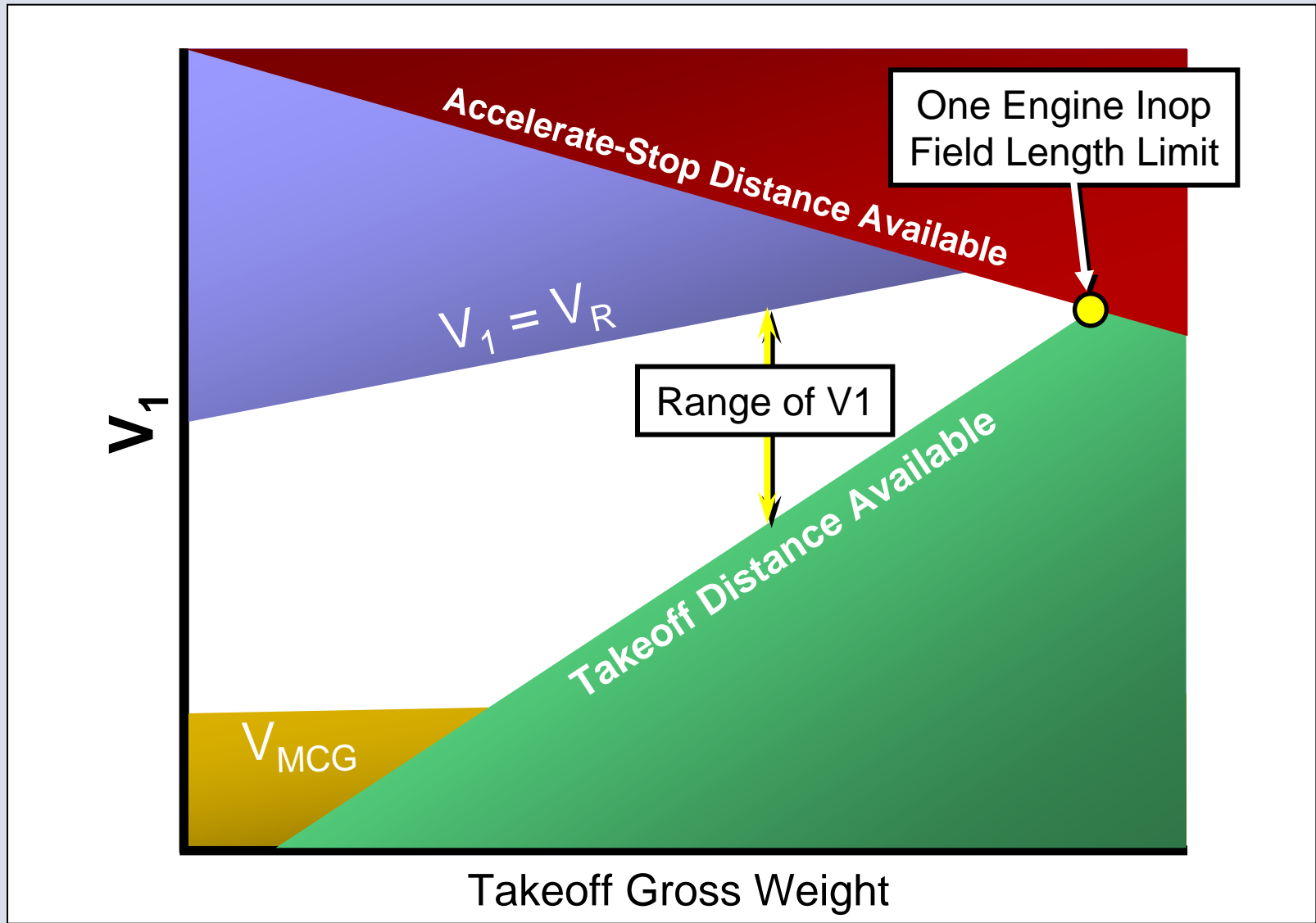

# Range of V1

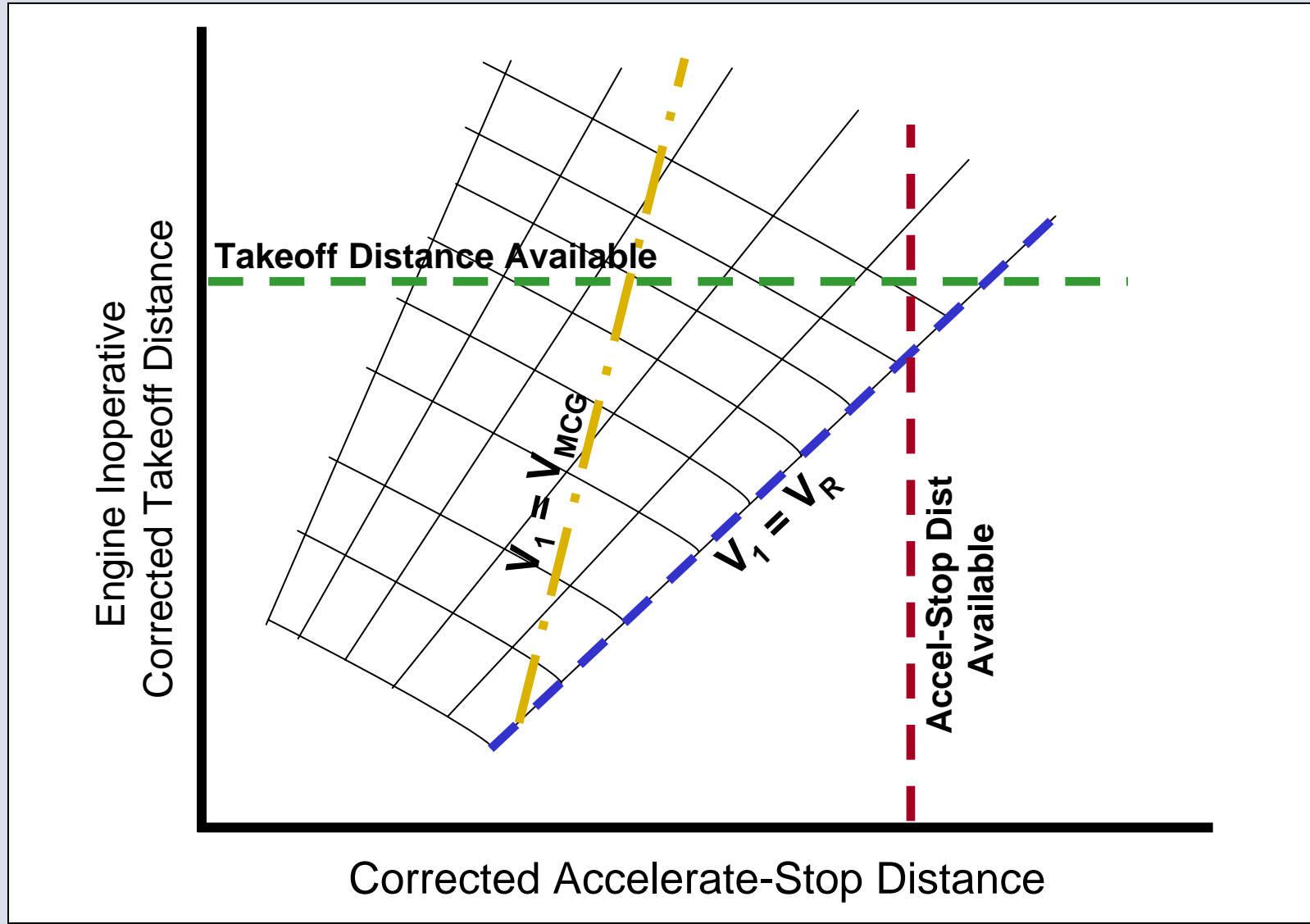

# Range of V1

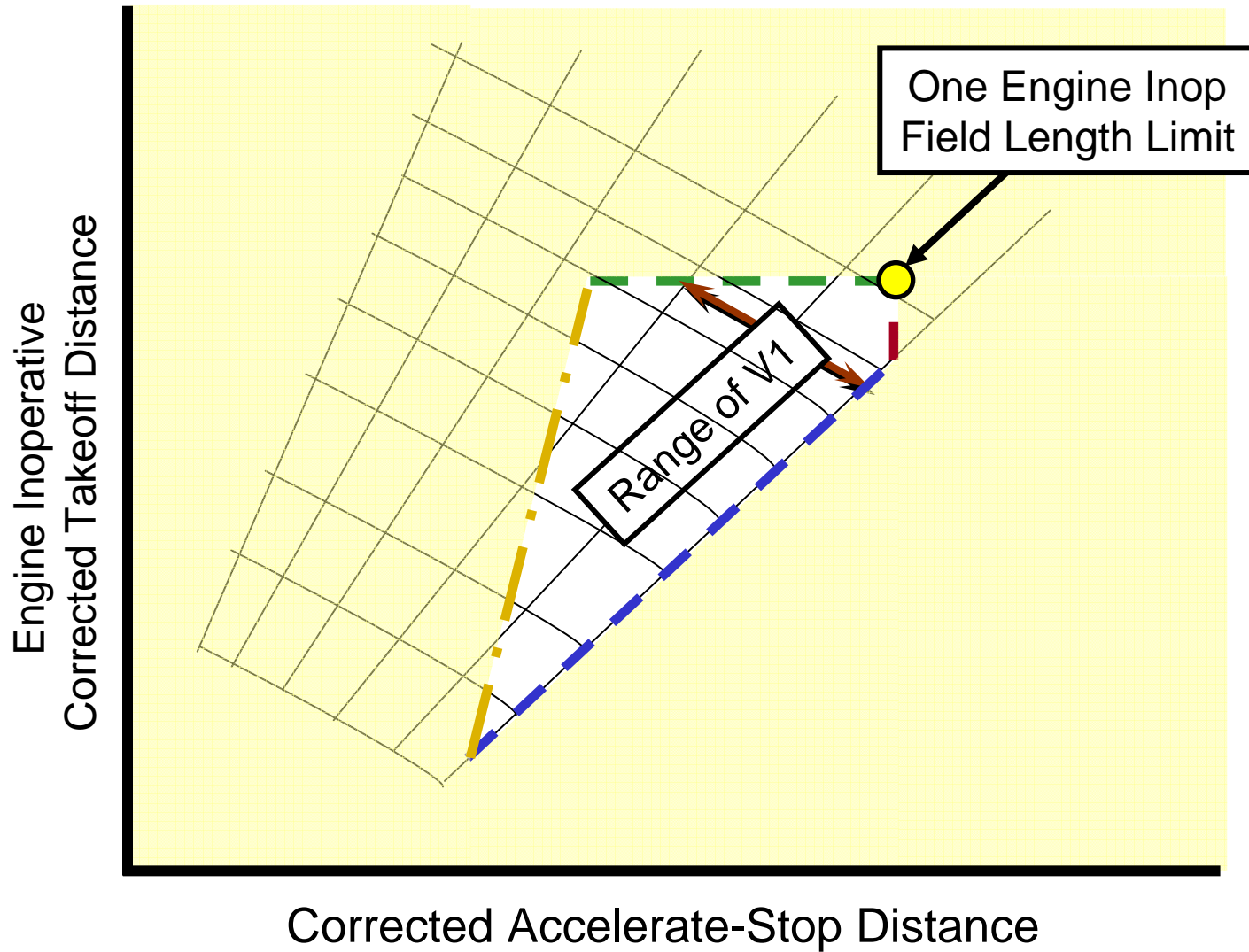

# 777 AFM-DPI Instructor-led Example:

Given:

- 777-200/Trent 892
- AIRPORT PRESSURE ALTITUDE = Sea Level
- AIRPORT TEMPERATURE = 30 DEG C
- RUNWAY LENGTH = 9500 FT
- SLOPE = 0%
- WIND = CALM
- NO CLEARWAY OR STOPWAY
- A/C ON
- ANTI-ICE OFF
- FLAPS 15

# 777 AFM-DPI Instructor-led Example:

Using AFM-DPI, Determine:

- Field length limit weight and V1
- Minimum, balanced, and maximum V1 at the following weights:
  - 240,000 kg, 260,000 kg, 280,000 kg
- For each weight, indicate the limiting factor on minimum and maximum V1

# AFM-DPI Demonstration

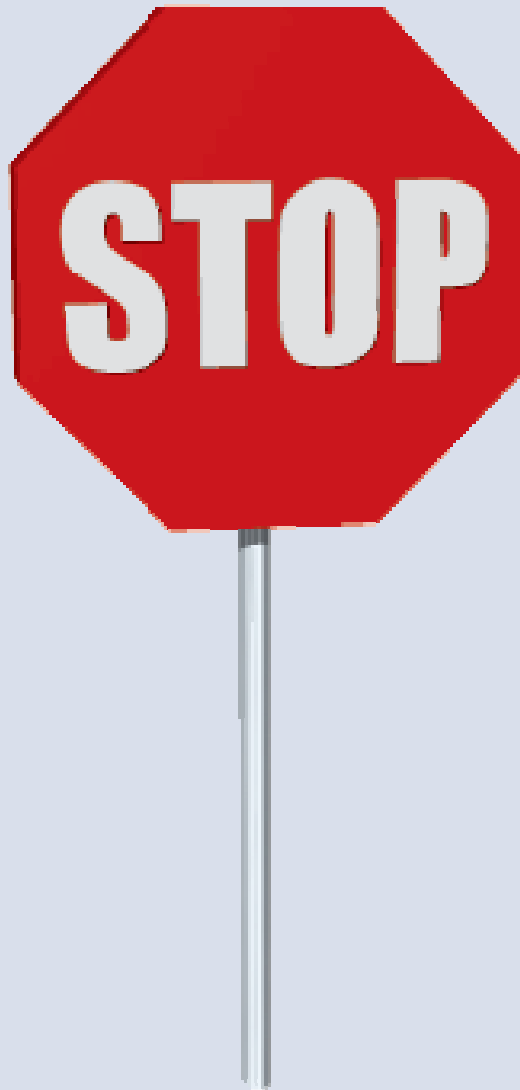

[AFM-DPI](#)

# 777 AFM-DPI Solution:

Using AFM-DPI, Determine:

- Field length limit weight and V1:

**FLGW = 281,239 kg, V1 = 150.7 KIAS**

- Minimum, balanced, maximum V1, and limiting factors at the following weights:

	<u>Min V1/limit</u>	<u>Bal V1</u>	<u>Max V1/limit</u>
240,000 kg:	<b>119.8/V<sub>1</sub>MCG</b>	<b>136.9</b>	<b>143.0/V<sub>R</sub></b>
260,000 kg:	<b>129.6/EOTOD</b>	<b>143.7</b>	<b>149.7/V<sub>R</sub></b>
280,000 kg:	<b>149.7/EOTOD</b>	<b>150.3</b>	<b>151.0/ASD</b>

# 777 "Web" chart

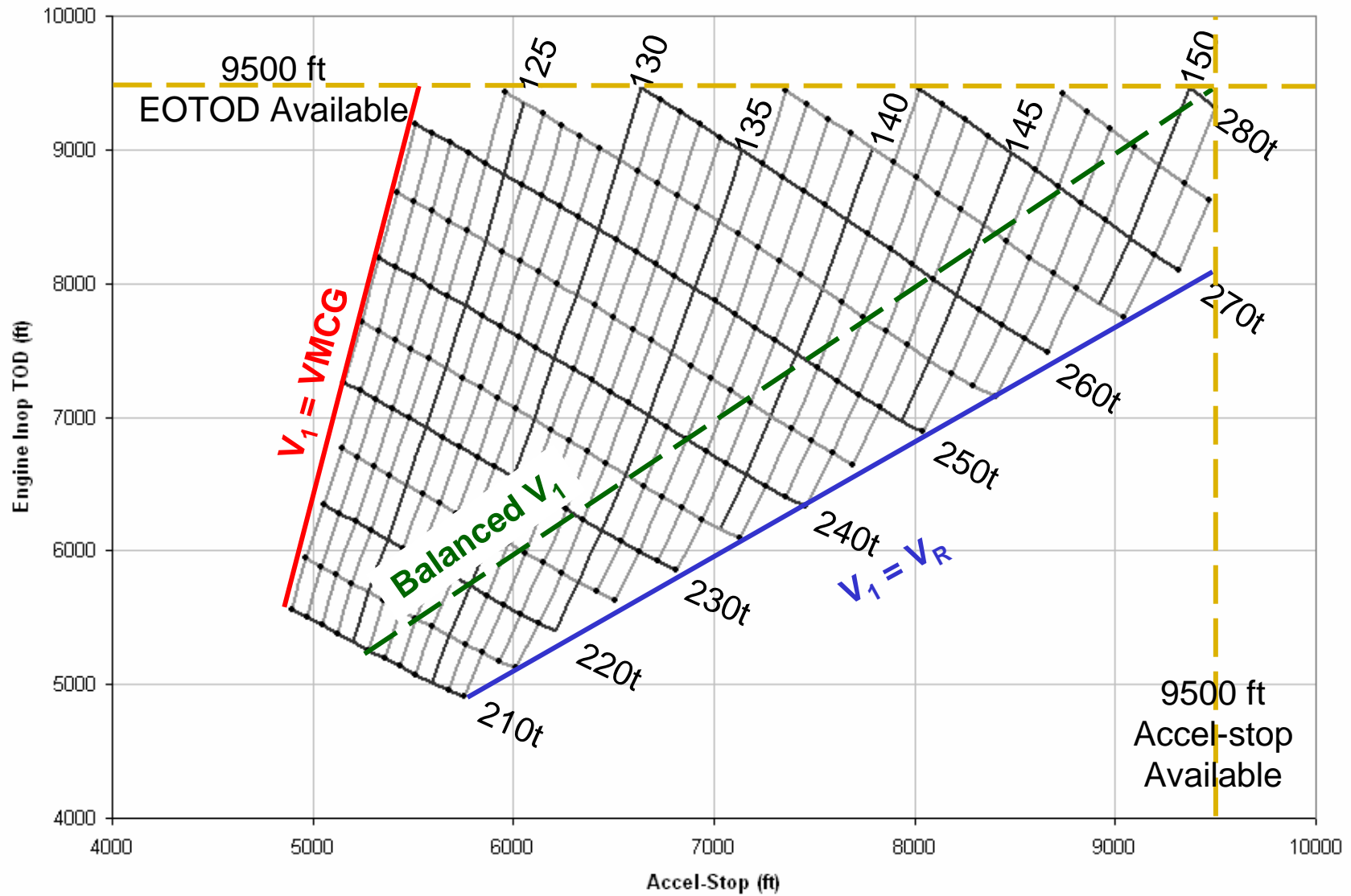

## 777 AFM-DPI Instructor-led Example:

Using AFM-DPI, Determine:

- At 270,000 kg, how much additional stop margin is introduced by selecting minimum V1 as opposed to balanced V1?
- What distance margin remains for continued takeoff following engine failure immediately prior to minimum V1?

# 777 "Web" chart

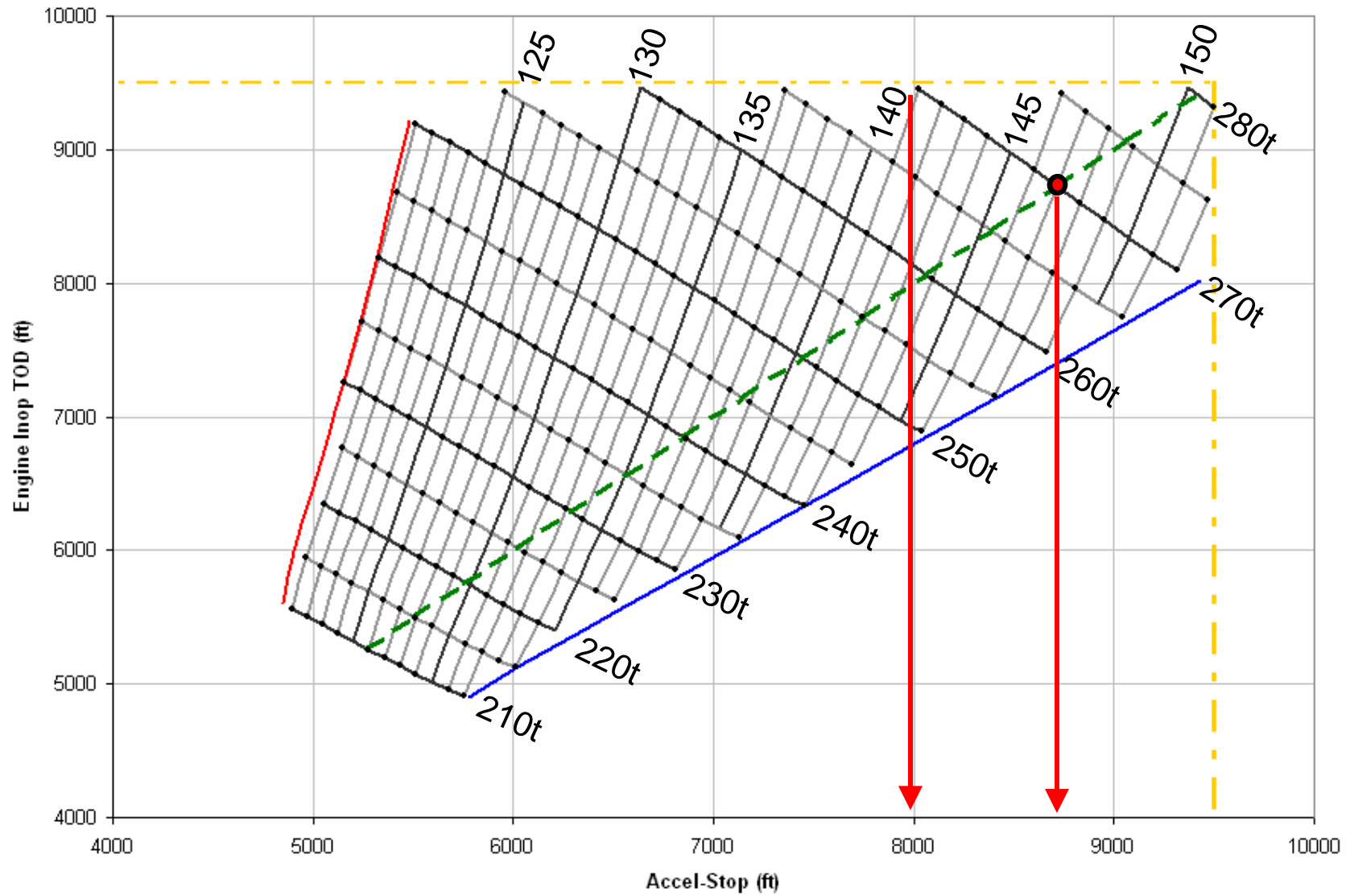

# 777-200/Trent892 distances

TEMP = 30C  
 ELEV = SEA LEVEL  
 TODA = ASDA = 9500 ft  
 NO WIND, NO SLOPE  
 A/C ON, FLAPS 15

		V1	Accel-Go	Accel-Stop
270000 kg	Bal V1	147.0 kts	8720 ft	8720 ft
	Min V1	140.6 kts	9500 ft	7984 ft
	<b>Delta</b>	<b>-6.4 kts</b>	<b>+780 ft</b>	<b>-736 ft</b>

		V1	Go Margin	Stop Margin
270000 kg	Bal V1	147.0 kts	780 ft	780 ft
	<b>Min V1</b>	<b>140.6 kts</b>	<b>0 ft</b>	<b>1516 ft</b>

# Range of V1 - Summary

- **Range of V1** can be used to optimize both performance and takeoff safety
- Within the allowable V1 Range, all Federal Aviation Regulations related to Maximum Takeoff Gross Weight, Field Length Limits, are satisfied.
- A **single V1** is chosen for each takeoff
- V1 within the allowable range can be chosen to maximize margins on either **Go** or **Stop**
- Statistical evidence from RTO accidents and incidents might lead us to consider a **Reduced V1 Policy**